

International Journal of Innovative Research in Science, Engineering and Technology

(A High Impact Factor, Monthly, Peer Reviewed Journal)

Visit: www.ijirset.com

Vol. 6, Issue 10, October 2017

Driver Face and Eye Movement Monitoring for Accident Avoiding System

Saranya.E¹, Madhu Mitha.M², P.Sajithira³, P.Nobelaskitta⁴, Raja S⁵

PG Students, Dept. of ECE, Sri Shakthi Institute of Engineering and Technology, Coimbatore, India^{1,2,3,4}

Assistant Professor, Dept. of ECE, Sri Shakthi Institute of Engineering and Technology, Coimbatore, India⁵

ABSTRACT: A Drowsy Driver Detection System has been developed, using a non-intrusive machine vision based concepts. Distracted driving is one of the main causes of vehicle collisions in the world. Passively monitoring a driver's activities constitutes the basis of an automobile safety system that can potentially reduce the number of accidents by estimating the driver's focus of attention. This project proposes an inexpensive vision-based system to accurately detect Eyes Off the Road (EOR). The system uses a small Raspberry Pi camera that points directly towards the driver's face and monitors the driver's eyes in order to detect fatigue. In such a case when fatigue is detected, a warning signal is issued to alert the driver. This report describes how to find the eyes, and also how to determine if the eyes are open or closed. The system deals with using information obtained for the binary version of the image. The eye regions in the face present great intensity changes, the eyes are located by finding the significant intensity changes in the face. Once the eyes are located, measuring the distances between the intensity changes in the eye area determine whether the eyes are open or closed. If the eyes are found closed for 5 consecutive frames, the system draws the conclusion that the driver is falling asleep and issues a warning signal.

KEYWORDS: Drowsy Driver Detection System, automobile safety system, Eyes off the Road, Raspberry Pi.

I. INTRODUCTION

A Drowsy Driver Detection System has been developed, using a nonintrusive machine vision based concepts. Driver distractions are the leading cause of most vehicle crashes and near-crashes. According to a study released by the National Highway Traffic Safety Administration (NHTSA) and the Virginia Tech Transportation Institute (VTTI), 80% of crashes and 65% of near-crashes involve some form of driver distraction. In addition, distractions typically occurred within three seconds before the vehicle crash. Recent reports have shown that from 2011 to 2012, the number of people injured in vehicle crashes related to distracted driving has increased 9%. In 2012 alone, 3328 people were killed due to distracted driving crashes, which is a slight reduction from the 3360 in 2011.

Distracted driving is defined as any activity that could divert a person's attention away from the primary task of driving. Distractions include texting, using a smart phone, eating and drinking, adjusting a CD player, operating a GPS system or talking to passengers. This is particularly challenging nowadays, where a wide spectrum of technologies have been introduced into the car environment. Consequently, the cognitive load caused by secondary tasks that drivers have to manage has increased over the years, hence increasing distracted driving. Especially concerning is the use of hand-held phones and other similar devices while driving. NHTSA has reported that texting, browsing, and dialing cause the longest period of drivers taking their Eyes off the Road (EOR) and increase the risk of crashing by three fold. A recent study shows that these dangerous behaviors are wide-spread among drivers, 54% of motor vehicle drivers in the United States usually have a cell phone in their vehicles or carry cell phones when they drive. Monitoring driver activities forms the basis of a safety system that can potentially reduce the number of crashes by detecting anomalous situations.

International Journal of Innovative Research in Science, Engineering and Technology

(A High Impact Factor, Monthly, Peer Reviewed Journal)

Visit: www.ijirset.com

Vol. 6, Issue 10, October 2017

II. LITERATURE SURVEY

Eye tracking and detection methods fall broadly within three categories, namely deformable templates, appearance-based, and feature-based methods. Deformable template and appearance-based methods are based on building models directly on the appearance of the eye region while the feature-based method is based on extraction of local features of the region. In general appearance models detect and track eyes based on the photometry of the eye region. A simple way of tracking eyes is through template-based correlation. Tracking is performed by correlation maximization of the target model in a search region. Grauman et al. [4] uses background subtraction and anthropomorphic constraints to initialize a correlation based tracker. Matsumoto and Zelinsky [5] present trackers based on template matching and stereo cameras. Excellent tracking performance is reported, but the method requires a fully calibrated stereo setup and a full facial model for each user. The appearance of eye regions share commonalities across race, illumination and viewing angle. Rather than relying on a single instance of the eye region, the eye model can be constructed from a large set of training examples with varying pose and light conditions. Based on the statistics of the training set a classifier can be constructed for detection purposes over a larger set of subjects. Eye region localization by Eigen images uses a subset of the principal components of the training data to construct a low-dimensional object subspace to represent the image data. Recognition is performed by measuring distances to the object subspace. The limitations of the methods, which are purely based on detection of eyes in individual frames, are that they do not make use of prior information from previous frames which can be avoided by temporal filtering.

Feature-based methods extract particular features such as skin-color, color distribution of the eye region. Kawato et al. [6] use a circle frequency filter and Background subtraction to track the in- between eyes area and then recursively binaries a search area to locate the eyes. Sommer et al. [7] utilize Gabor filters to locate and track the features of eyes. They construct a model-based approach which controls steerable Gabor filters: The method initially locates particular edge (i.e. left corner of the iris) then use steerable Gabor filters to track the edge of the iris or the corners of the eyes. Nixon demonstrates the effectiveness of the Hough transform modeled for circles for extracting iris measurements, while the eye boundaries are modeled using an exponential function. Young et al. [8] show that using a head mounted camera and after some calibration, an ellipse model of the iris has only two degrees of freedom (corresponding to pan and tilt). They use this to build a Hough transform and active contour method for iris tracking using head mounted cameras. propose the Fast Radial Symmetry Transform for detecting eyes in which they exploit the symmetrical properties of the face. Explicit feature detection (such as edges) in eye tracking methods relies on thresholds. In general defining the thresholds can be difficult since light conditions and image focus change. Therefore, methods on explicit feature detection may be vulnerable to these changes.

III. PROPOSED SYSTEM

The proposed drowsy detection system consists of major steps of operation. They are Image acquisition, Binarization and Eye detection, and Drowsiness Detection Function. In this system first capture the face image using IR camera. The IR camera is interfaced with Raspberry pi. Then the captured images are processed by Raspberry pi processor. Then linearization and Drowsiness Detection are performed through mat lab. It finds out position of eye, whether Eye open or closed. If Open Eye Image is detected then signal gets no drowsy found, buzzer is OFF. If Closed Eye Image is detected then signal gets drowsy found, buzzer is ON. The proposed system develops a drowsiness detection system that will accurately monitor the open or closed state of the driver's eyes in real-time.

IV. HARDWARE DESCRIPTION

The eye tracking system is based on intensity changes on the eye, it is crucial that the background does not contain any object with strong intensity changes. Highly reflective object behind the driver, can be picked up by the camera, and be consequently mistaken as the eyes. Low surrounding light (ambient light) is also important, since the only significant light illuminating the eye should come from the drowsy driver system. If there is a lot of ambient light, the effect of the light source diminishes.

International Journal of Innovative Research in Science, Engineering and Technology

(A High Impact Factor, Monthly, Peer Reviewed Journal)

Visit: www.ijirset.com

Vol. 6, Issue 10, October 2017

Raspberry Pi Camera

The Raspberry Pi camera module can be used to take high-definition video, as well as stills photographs. The module has a five megapixel fixed-focus camera that supports 1080p30, 720p60 and VGA90 video modes, as well as stills capture. It attaches via a 15cm ribbon cable to the CSI port on the Raspberry Pi. It can be accessed through the MMAL and V4L APIs, and there are numerous third-party libraries built for it, including the Pi camera Python library. The camera module is very popular in home security applications, and in wildlife camera traps. You can also use it to take snapshots. The video and still image quality is better than a USB webcam of similar price.

The facial image data is in 480x640 pixel format and is stored as an array through the pre-defined Picolo driver functions. The image is captured from the video, where image is numeric representation (normally binary) of a two dimensional image. The video is acquired by using raspberry pi camera module. The camera provides 30 frames per second at VGA mode. Then the recorded video is opened in MATLAB and the frames are grabbed, then the algorithm is run on every frame detecting the driver's vigilance. The "Pi NoIR" version of the camera was released on the 28th of October 2013. It has the same sensor with the IR filter removed, and a black PCB. Withno IR filter, it can see near-IR wavelengths (700 - 1000 nm) like a security camera, with the tradeoff of poor colour rendition. It is otherwise the same and uses the same software as the normal Pi camera.

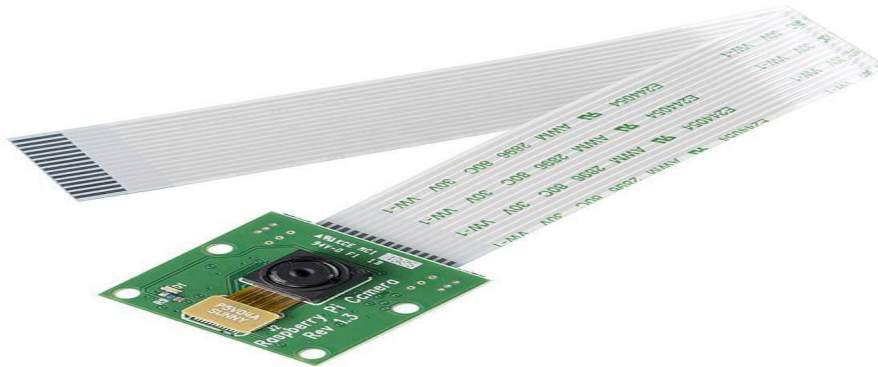

Figure. 1 Image of Raspberry Pi Camera

Light Source

The conditions when ambient light is poor (night time), a light source must be present to compensate. Initially, the construction of an infrared light source using infrared LED was implemented. It was found that at least 50 LEDs would be needed so create a source that would be able to illuminate the eye.

IR Illuminator

The night time operation an illuminator can be used as a spot light to provide a clear image of the driver's face. There are many types of illumination devices including LED Light, laser type and filtered incandescent lamps. And the illumination system cannot affect the driver's vision.

International Journal of Innovative Research in Science, Engineering and Technology

(A High Impact Factor, Monthly, Peer Reviewed Journal)

Visit: www.ijirset.com

Vol. 6, Issue 10, October 2017

Buzzer

A buzzer is an audio signaling device, which may be mechanical, electromechanical, or piezoelectric. It most commonly consists of a number of switches or sensors connected to a control unit that determines if and which button was pushed or a preset time has lapsed, and usually illuminates a light on the appropriate button or control panel, and sounds a warning in the form of a continuous or intermittent buzzing or beeping sound. Initially this device was based on an electromechanical system which was identical to an electric bell without the metal gong (which makes the ringing noise).. Another implementation with some AC-connected devices was to implement a circuit to make the AC current into a noise loud enough to drive a loudspeaker and hook this circuit up to a cheap 8-ohm speaker. Nowadays, it is more popular to use a ceramic-based piezoelectric sounder like a Sonalert which makes a high-pitched tone. Usually these were hooked up to "driver" circuits which varied the pitch of the sound or pulsed the sound on and off.

Raspberry Pi B+ Model

. A system on a chip or system on chip (SoC) an integrated circuit (IC) that integrates components of a computer or other electronic system into a single chip. It may contain digital, analog, mixed-signal, and often radio-frequency functions—all on a single chip substrate. SoCs are very common in the mobile electronics market because of their low power consumption. A typical application is in the area of embedded systems.

The contrast with a microcontroller is one of degree. Microcontrollers typically have under 100 kB of RAM (often just a few kilobytes) and often really are single-chip-systems, whereas the term SoC is typically used for more powerful processors, capable of running software such as the desktop versions of Windows and Linux, which need external memory chips (flash, RAM) to be useful, and which are used with various external peripherals. In short, for larger systems, the term system on a chip is a hyperbole, indicating technical direction more than reality: increasing chip integration to reduce manufacturing costs and to enable smaller systems. Many interesting systems are too complex to fit on just one chip built with a process optimized for just one of the system's tasks.

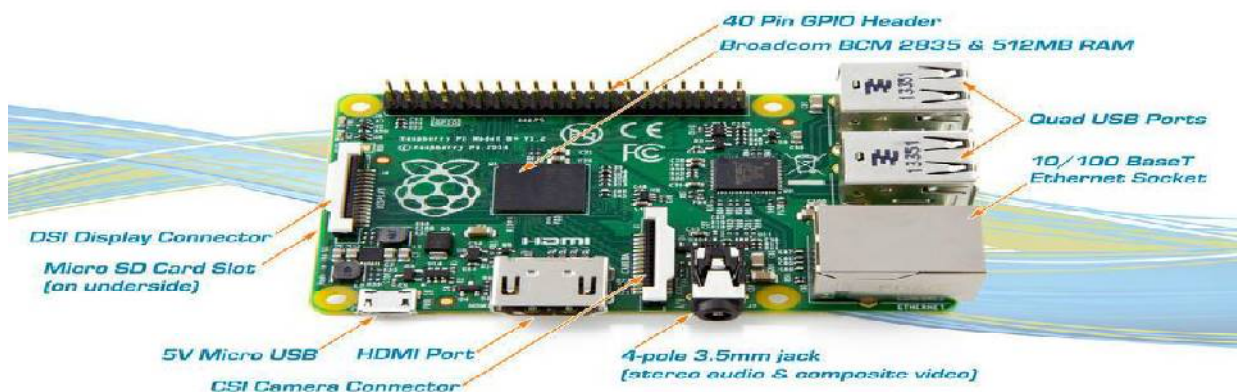

Figure 2 Image of Raspberry Pi

GPIO of B+ Model (GPIO – General Purpose Input Output)

General-purpose input/output (GPIO) as shown in figure 3.3 is a generic pin on an integrated circuit whose behavior, including whether it is an input or output pin, can be controlled by the user at run time. GPIO pins have no special purpose defined, and go unused by default. The idea is that sometimes the system designer building a full system that

International Journal of Innovative Research in Science, Engineering and Technology

(A High Impact Factor, Monthly, Peer Reviewed Journal)

Visit: www.ijirset.com

Vol. 6, Issue 10, October 2017

uses the chip might find it useful to have a handful of additional digital control lines, and having these available from the chip can save the hassle of having to arrange additional circuitry to provide them.

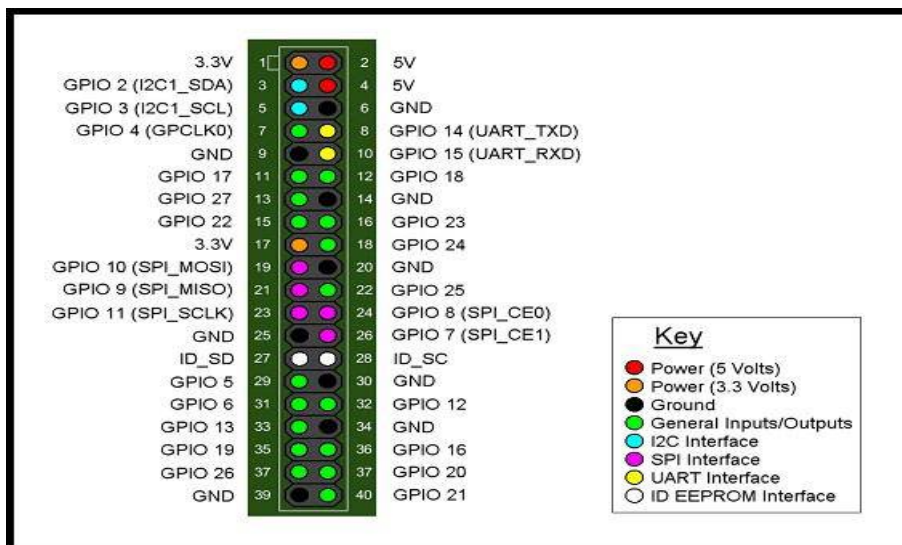

Figure 3 GPIO connector on Raspberry Pi

V. DESIGN OF PROTOTYPE

The given below block diagrams are the prototype design of the driver drowsiness detection system. The general block diagram and block diagram of MATLAB are discussed below. The main component of the prototype model is Raspberry Pi B+ model and Raspberry Pi camera. The function of the system is, when the person is sleepy the buzzer is ON. When the person is not sleepy the buzzer is OFF.

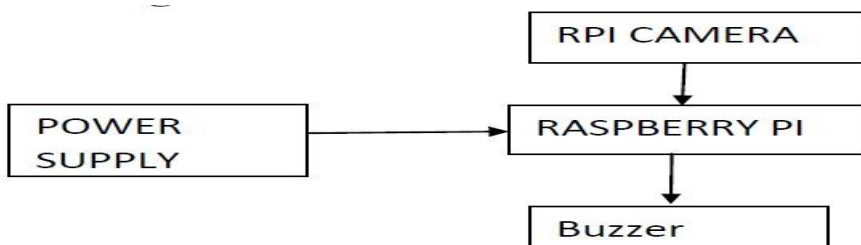

Figure 4 General block diagram of proposed system

The figure 3.4 is the general block diagram for Drowsiness Detection System. The power supply (5v) is given to the Raspberry Pi. The IR camera will take the snap shot of face image initially. The image is converted to binary image, later when the person is drowsy the IR camera will capture the image and it will compare to the previous image. If the drowsiness is detected the vibrator will starts to vibrate. If the person is not found drowsy then the vibrator will stop vibrating.

International Journal of Innovative Research in Science, Engineering and Technology

(A High Impact Factor, Monthly, Peer Reviewed Journal)

Visit: www.ijirset.com

Vol. 6, Issue 10, October 2017

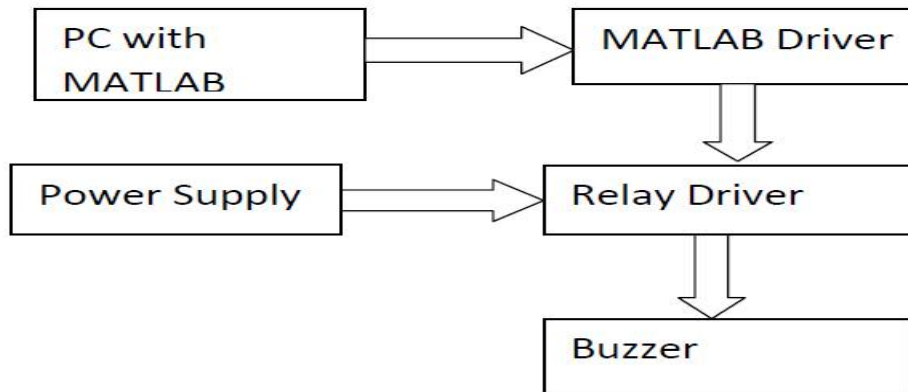

Figure 5 Proposed block diagram of MATLAB

Drowsiness Detection can make use of extended version of Viola-Jones algorithm, which is available in Computer Vision System Toolbox of MATLAB. In this system whether the eye is open or closed output by using mat lab coding given to mat lab driver. Then the signals (USB to Serial port) are given to the relay that control the speed of car and ringing the alarm when eye get closed. The system hardware is to be designed in such a way that it should process the signals from the software generated program and produce the desired output. It should contain a mechanism for processing the output from the software and work out for the decision that is to make the user aware of the drowsiness and possibly raise an alarm as shown in figure 3.5. We would need a serial port connector to connect the software part to the hardware kit. We need to design separate power supply for the working of onboard mechanism. We need a set of mat lab drivers on the kit for processing the signal from software to hardware and also the mechanism to work out the signal to a follow up procedure that is rising up an alarm or other mechanisms.

VI. RESULTS AND DISCUSSIONS

All the algorithms are implemented in MATLAB R2015b and these programs are tested in Windows 8 64bit operating system. This algorithm is tested with real time videos. The real time videos are captured using raspberry pi camera module. Videos are converted in to sequence of frames for the purpose of testing. The table 1 shows the analysis of the detecting drowsiness

Sl No	Criterion used to find drowsiness	Number of Drowsiness Detected	Correct Drowsiness Detected
1	Duration of eyelid closure	20	20
2	Number of groups of continuous blinks.	18	16
3	frequency of eye blink	10	8

Table 1 Analysis of Drowsiness Detection

International Journal of Innovative Research in Science, Engineering and Technology

(A High Impact Factor, Monthly, Peer Reviewed Journal)

Visit: www.ijrset.com

Vol. 6, Issue 10, October 2017

The below given figures are the prototype working model of the project. The coding are performed in MATLAB software to detect the drowsiness.



Figure 6 Interfacing of Raspberry Pi and Camera Module

The figure 4. 1 is interfacing of Raspberry Pi B+ model and the camera module to capture the image of the driver and detect the drowsiness by opening and closing of the eye



Figure 7 Setup of Drowsiness Detection System

The figure 4.2 is the entire setup of the project, the motor and buzzer is connected to the GPIO pin of the Raspberry Pi. When the drowsiness is detected the buzzer is ON. When drowsiness is not detected the buzzer is OFF.

International Journal of Innovative Research in Science, Engineering and Technology

(A High Impact Factor, Monthly, Peer Reviewed Journal)

Visit: www.ijirset.com

Vol. 6, Issue 10, October 2017

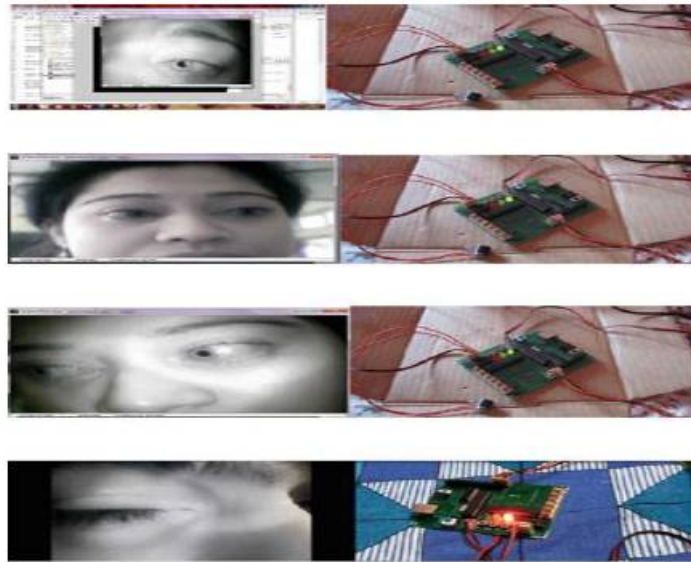

Figure 8 Sample Output For Eye Detection System

VII.CONCLUSION

A non-invasive system to localize the eyes and monitor fatigue was developed. Information about the eyes position is obtained through various self-developed image processing algorithms. During the monitoring, the system is able to decide if the eyes are opened or closed. When the eyes have been closed for too long, a warning signal is issued .If the person is not alert for a time the engine is off automatically. In addition, during monitoring, the system is able to automatically detect any eye localizing error that might have occurred. In case of this type of error, the system is able to recover and properly localize the eyes.Currently there is not adjustment in zoom or direction of the camera during operation. Future work may be to automatically zoom in on the eyes once they are localized. This would avoid the trade-off between having a wide field of view in order to locate the eyes, and a narrow view in order to detect fatigue. Adaptive linearization is an addition that can help make the system more robust. This may also eliminate the need for the noise removal function, cutting down the computations needed to find the eyes. This will also allow adaptability to changes in ambient light .In future work; we will incorporate motion capture and EEG facilities to our experimental setup. The motion capture system will enable analyzing the upper torso movements. In addition the EEG will provide a ground-truth for drowsiness. Capture individual driver's steering activity while drowsy, Conduct additional simulator experiments to validate the algorithm, test additional road conditions, and test a more diversified group of drivers.

REFERENCES

- [1] E. Murphy-Chutorian and M. M. Trivedi, —Head pose estimation in computer vision: A survey,| Pattern Analysis and Machine Intelligence, IEEE Transactions on, vol. 31, no. 4, pp. 607–626, 2009.N. Alexandratos and J. Bruinsma, *World Agriculture Towards 2030/2050:The 2012 Revision*. Quebec City, QC, Canada: Food and Agriculture Organization of the United Nations, 2012.
- [2] R. Hassanpour and V. Atalay, —Delaunay triangulation based 3d human face modeling from uncelebrated images,| in Computer Vision and Pattern Recognition Workshop, 2004. CVPRW'04.Conference on. IEEE,2004, pp. 75–75.
- [3] Matsumoto Y, Zelinsky A (2000) An algorithm for real-time stereo vision Implementation of Head pose and gaze direction measurements. In: Proceedings of IEEE 4th international conference on face and gesture recognition, pp 499–505
- [4] Yuille AL, Hallinan PW, Cohen DS (1992) Feature extraction from faces using deformable templates. Int J Comput Vis 8(2):99–111
- [5] Sommer G, Michaelis M, Hergers R (1998) The SVD approach for steerable filter design. In: Proceedings of international symposium on circuits and systems 1998, Monterey, California,vol 5, pp 349–353
- [6] Yang G, Waibel A (1996) A real-time face tracker. In: Workshop on applications of computer vision, pp 142–147



ISSN(Online): 2319-8753
ISSN (Print): 2347-6710

International Journal of Innovative Research in Science, Engineering and Technology

(A High Impact Factor, Monthly, Peer Reviewed Journal)

Visit: www.ijirset.com

Vol. 6, Issue 10, October 2017

- [7] Loy G, Zelinsky A (2003) Fast radial symmetry transform for detecting points of interest. IEEE Trans Pattern Anal Mach Intell 25(8):959-973.
- [8] Ivins JP, Porrill J (1998) A deformable model of the human iris for measuring small-dimensional eye movements. Mach Vis Appl 11(1):42-51
- [9] Kawato S, Tetsutani N (2002) Real-time detection of between-the-eyes with a circle frequency filter. In: Asian conference on computer vision.